

N^o 15,638



A.D. 1901

Date of Application, 2nd Aug., 1901

Complete Specification Left, 1st May, 1902—Accepted, 12th June, 1902

PROVISIONAL SPECIFICATION.

Improvements in Variable Gearing for Velocipedes and Road Motor Vehicles.

I, JAMES ARCHER, of 17 Linwood Street, Hulme, Manchester, Cycle Engineer, do hereby declare the nature of my said invention to be as follows:—

This invention relates chiefly to the driving gear of velocipedes and its object is to provide mechanism by which the rider may have the option of using three different gears or speeds 'low', 'high', 'normal' and a 'free wheel' as desired, and so constructed and arranged that the rider may change the gears whilst riding. A further object is to so construct the parts that the 'high' and 'low' gear mechanism may be applied to or removed from the machine without affecting the 'normal' gear.

10 According to the invention and as applied to the rear wheel of a safety bicycle I provide one end of the hub with a cup bearing and upon the inner side of such bearing I form or provide a clutch. The other end of the hub I provide with a ring or bush which fits neatly and detachably in the hub up to a shoulder or abutment. This ring has a ball race on one side and a similar
15 ring adjoins it with a like race. This latter is identified with a sleeve (hereafter called the driving sleeve) and upon such sleeve is mounted the usual sprocket or chain wheel. Such driving sleeve is also formed with a cup bearing at one end and at the other end within the hub is formed or provided with two clutches.

20 In the hub is an annular cavity and in such cavity a set of pawls.

Such annular cavity and pawls may be replaced by a fixed annular clutch.

Within the hub is a further sleeve (hereinafter called the gear ring) having internal teeth formed at one end and capable of endwise and rotary movement. In the periphery of such gear ring is a ring of ratchet teeth, also an annular
25 recess with inclined sides, and the position of the gear ring, and its movements in relation to the pawls in the hub cavity, are such that the pawls may engage the ratchet teeth, and act as a 'free wheel' in one direction, or be raised on to the plain part of the gear ring entirely out of action.

This gear ring has a clutch on one end adapted to engage with one of the
30 clutches on the driving sleeve, and when so engaged the pawls may, by means of the inclines of the annular recess aforesaid, be raised out of action.

Within the gear ring I arrange a 'planet-cage', carrying, upon studs and between suitable flanges, three or more planet pinions meshing with a pinion concentric with the axle, also with the said inner teeth on the gear ring, and
35 upon each end of the 'planet-cage' I form further clutches, and such clutches are directly in line with, and respectively opposite to, the clutches on the cup bearing, and the driving sleeve. The 'planet-cage' and gear ring are laterally coupled together and the endwise movements of the same are such that as the clutch of the gear ring engages with one of the clutches on the driving sleeve,
40 the clutch of the 'planet-cage' engages with the hub (or *vice versa*) thus giving a change of gear.

When both clutches are disengaged the pawls in the hub engage the driving sleeve and thus give the 'normal' gear.

[Price 8d.]



Improvements in Variable Gearing for Velocipedes and Road Motor Vehicles.

In such way, and by such means I provide three changes of gear, 'high', 'low', 'normal', and allow for the ready introduction or withdrawal of the 'high' and 'low' speed gears from the hub without altering the 'normal' gear.

The pinion on the axle is a fixture. 5

The sprocket wheel may be loose on the driving sleeve and be fitted with free wheel devices, but I prefer it to be fast and to be held by a nut or screwed ring screwing against it. Other variations in details may be made, and the position of the gears varied without departing from my invention.

The endwise movements of the mechanism may be secured by means of a sliding feather within the axle, or by a hollow spindle and cross feather engaging with the 'planet-cage', or by any suitable device. 10

Dated this 1st day of August 1901.

JAMES ARCHER,

By John G. Wilson & Co., 15
Manchester, Agents.

COMPLETE SPECIFICATION.

Improvements in Variable Gearing for Velocipedes and Road Motor Vehicles,

I, JAMES ARCHER of 17 Linwood Street, Hulme, Manchester, Cycle Engineer, 20
do hereby declare the nature of this invention and in what manner the same is to be performed, to be particularly described and ascertained in and by the following statement:—

This invention relates chiefly to the driving gear of velocipedes, and its object is to provide mechanism by which the rider may have the option of using three different gears or speeds 'low', 'normal', 'high' and a 'free wheel' as desired, and so constructed and arranged that the rider may change the gears whilst riding. A further object is so to construct the parts that the 'high' and 'low' gear mechanism may be applied to, or removed from the machine without affecting the 'normal' gear. 25 30

According to the invention, and as applied to the rear wheel of a safety bicycle, I provide one end of the hub with a cup bearing, and upon the inner side of such bearing I form or provide a clutch. The other end of the hub I provide with a ring or bush which fits neatly and detachably in the hub up to a shoulder or abutment. This ring has a ball race on one side and a similar ring adjoins it with a like race. This latter is identified with a sleeve (hereafter called the driving sleeve) and upon such sleeve is mounted the usual sprocket or chain wheel. Such driving sleeve is also formed with a cup bearing at one end, and at the other end within the hub is formed or provided with two clutches. In the hub is an annular cavity and in such cavity a set of pawls. Such annular cavity and pawls may be replaced by a fixed annular clutch. 35 40

Within the hub is a further sleeve (hereinafter called the gear ring) having internal teeth formed at one end and capable of endwise and rotary movement. In the periphery of the gear ring is a ring of ratchet teeth, also an annular recess with inclined sides, and the position of the gear ring and its movements in relation to the pawls in the hub cavity, are such that the pawls may engage the ratchet teeth, and act as a 'free wheel' in one direction, or be raised on to the plain part of the gear ring entirely out of action. 45

When the pawls engage the ratchet teeth of the gear ring the hub is driven at the 'high' gear. 50

Improvements in Variable Gearing for Velocipedes and Road Motor Vehicles.

This gear ring has a clutch on one end adapted to engage with one of the clutches on the driving sleeve.

Within the gear ring I arrange a 'planet-cage' carrying upon studs and between suitable flanges, three or more planet pinions meshing with a pinion
5 concentric with the axle, also with the said inner teeth on the gear ring, and upon each end of the planet-cage I form further clutches, and such clutches are directly in line with and respectively opposite to clutches on the cup bearing and the driving sleeve. The 'planet-cage' and gear ring are laterally
10 coupled together and the endwise movements of the same are such that as the clutch of the gear ring engages with one of the clutches on the driving sleeve, the clutch of the 'planet-cage' engages with the hub, thus giving a change of gear

When both clutches are disengaged the pawls in the hub engage the driving sleeve and thus give the 'normal' gear.

In such way and by such means I provide for three changes of gear, 'high'-
15 'low',-'normal',- and allow for the ready introduction or withdrawal of the 'high' and 'low' speed gears from the hub without altering the 'normal' gear.

The pinion on the axle is a fixture.

The sprocket wheel may be loose on the driving sleeve and be fitted with 'free
20 wheel' devices, but I prefer it to be fast and to be held by a nut or screwed ring screwing against it. Other variations in details may be made, and the position of the gears varied without departing from my invention.

The endwise movements of the mechanism may be secured by means of a sliding feather in the axle, or by a hollow spindle and cross-feather engag-
25 ing with the planet-cage or by any suitable device.

To permit of my invention being more clearly understood I have hereunto appended 2 sheets of drawings, wherein

Fig. 1 illustrates a longitudinal elevation, partly sectional, of a wheel hub fitted with my invention and as adapted for giving the three gears,—'low',
30 'normal', 'high' and the 'high' and 'normal' gears free. Such view also shews the position of the parts for the 'low' gear.

Figs. 2 and 3 illustrate like views, but Fig. 2 shews a plan and the position of the parts for giving the 'normal' gear, and Fig. 3 shews the position of the parts for giving the 'high' gear.

35 Fig. 4 illustrates a half exterior and half longitudinal section of the 'planet-cage' and gear ring. Fig. 5 illustrates a cross-section on lines *a-b*.

Fig. 6 illustrates a transverse section of Fig. 2 on line *c-d*, and Fig. 7 illustrates a half exterior and half longitudinal section of the 'driving sleeve'.

Fig. 8 illustrates an inner side view of the hub-bush or cup bearing shewn at
40 the left hand end of Fig. 1, and part of the 'low' gear, and Fig. 9 illustrates a side view of the left-hand end of the 'planet-cage', and another part of the 'low' gear. Fig. 10 illustrates a sectional view of the gear ring alone, and Fig. 11 illustrates a detached view of the wheel axle.

Figs. 12, 13 and 14 illustrate a modification, and the several positions of the
45 gears for the three speeds.

Referring to Figs. 1 to 11,—(1) is the hub of say the rear wheel of a safety bicycle more or less of ordinary construction. Within such hub is the hollow axle (2) held stationary, relatively to the hub, by the usual forks or members (3) of the bicycle frame, the ball bearings (4) and nuts (5). Upon, or formed in
50 such axle is a fixed ring of gear teeth, constituting a fixed pinion (6), and in a plain portion of such axle is a slot (7). In one end of the hub, and supporting the hub concentric to the axle, is the bush or cup bearing (8), and upon the inner face of such bush are clutch teeth (9).

At the other end of the hub, and supporting the hub concentric with the axle
55 at that end, is the ball bearing (4) aforesaid, the sleeve or bush (10) (hereinafter and previously called the driving sleeve) see Fig. 7, and the ball race rings

Improvements in Variable Gearing for Velocipedes and Road Motor Vehicles.

(11), (12), with anti-friction balls (13) between them, and fitting against a shoulder in the hub as shewn.

Upon the driving sleeve is the chain or sprocket wheel (14) held tightly thereon and against the ring (12) by the clamping nut (15).

Upon the periphery of the driving sleeve within the hub are the two rings of clutch teeth (16), (16^x), the latter being, by preference in the form of ratchet teeth and upon the interior of the hub are the pawls (17), (17^x). The pawls (17) are of the shape shewn in Fig. 1 and 2, and the pawls (17^x) are of the shape shewn in Fig. 3.

Within the hub, and surrounding the axle, is the gear ring (23), see Fig. 10, 10 having an internal ring of gear teeth (24), an internal ring of clutch teeth (25), an external ring of ratchet teeth (26), and an annular groove (27) with inclined sides. Coupled laterally and loosely by a ring (28) to such gear ring is the 'planet-cage', comprising a tubular part (29) carrying studs (30), and pinions (31) loosely mounted on the said studs, 15 and held thereon by a flange (32) having clutch teeth (or nipples) (33). The pinions (31) mesh at all times with the pinion (6) on the axle.

Upon the tubular part (29) is also the clutch teeth (9^x).

In the driving sleeve (10) is a clutch (34), either in the form of holes, or teeth and corresponding in spacing from each other and in the distance from the axle (2) with the spacing and distance of the teeth (33). 20

With the 'planet-cage' and gear ring in the position shewn in Fig. 1 the hub is driven at the 'low' speed,—the driving taking place through the clutch teeth (16) and (25), the gear ring (23), the pinions (31), studs (30), tubular part (29) and the clutch teeth (9) and (9^x), the pinion (6) offering the necessary 25 resistance to cause the pinions (31) to rotate on their studs (30) as they are rolled around the axle by the teeth (24), and thus reduce the speed. The pawls (17), (17^x) both rest upon the plain part (23^x) of the gear ring.

With the 'planet-cage' and gear ring in the position shewn in Fig. 2 the hub is driven at the 'normal' speed,—the driving taking place direct through the 30 teeth (16^x) and pawls (17^x) the planet-cage and gear ring being idle.

With the planet-cage and gear ring in the position shewn in Fig. 3 the hub is driven at the 'high' speed,—the driving taking place through the teeth or bosses (33) engaging the holes (or teeth) (34), pinions (31), gear ring (23), the ratchet teeth (26) and pawls (17^x). At such speed the pawls (17) rotating faster 35 slip over the teeth (16^x), the pawls (17^x) alone effecting the drive and hence the two sets of pawls.

The means for bringing about the lateral movements of the 'planet-cage' and gear ring may vary, but in practice I have found the arrangement of cord, cross-bar and springs covered by my application for Letters Patent, No. 519, 40 A.D. 1902 as the most satisfactory, and in now describing and illustrating the same I hereby give public notice that I do not dedicate the said devices, or any part thereof, not claimed in this specification to the public, but simply refer to them as being the best means known to me for the said purpose.

Within the tubular (29) is a spiral spring (35), also a thimble-like part (36) 45 with contact ring (37), and in the slot (7) of the axle is the cross-bar or feather (38), the ends of which project on each side of the axle and normally lie behind the flanged end of the thimble-like part (36) as shewn. To such cross-bar is attached one end of say a 'Bowden' wire, a chain, or the like the other end of which passes out through the open end of the axle and from thence extends to 50 the point from which the gears are to be operated.

Around the axle (2) and within the spring (35) I place a further spring (39). Under the elongation of this spring the normal position of the parts is as shewn in Fig. 3.

To obtain the 'normal' gear the cord or chain is pulled and the bar (38) 55 thereby caused to press against the thimble-like part (36) and through the spring (35), move the planet-cage and gear ring to the position shewn in Fig. 2, the spring (39) being thereby slightly compressed.

Improvements in Variable Gearing for Velocipedes and Road Motor Vehicles.

To obtain the 'low' gear the cord or chain is given a further pull, thereby causing the bar (38) to move the 'planet-cage' and gear ring to the position shewn in Fig. 1, the spring (39) being thereby still further compressed.

Should the clutches (9), (9^x) not be relatively opposite the spring (35) is slightly compressed so that immediately the gears rotate the clutches engage under the elongation of the spring (35). Upon the cord or chain being relaxed, the spring (39) serves to change the gears by its elongation.

Referring to Figs. 12, 13 and 14, a fixed clutch ring (40) is substituted for the pawls (17), (17^x), and the clutch teeth (41) for the ratchet teeth (26). The ratchet teeth (16) are dispensed with, and the clutch teeth (16) are made wider, and in lieu of the flange (32) with clutch teeth (33) I use the studs (30) engaging with clutch recesses or holes (34^x) thereby simplifying the construction.

The position of the parts for the 'low' gear is as shewn in Fig. 12, the position of the parts for the 'normal' gear is as shewn in Fig. 13, and the position of the parts for the 'high' gear is as shewn in Fig. 14. All the gears in this modification are fixed in both directions. To obtain the 'free wheel' effect for each gear I employ an ordinary 'free wheel' attachment, in lieu of the sprocket wheel (14).

The several clutches may be in the form of segmental teeth, or in the form of spur teeth, or ratchet teeth.

Whilst chiefly for velocipede use my invention applies equally to road motor vehicles, and in the case of Figs. 1, 2 and 3.

It will be seen that by removing the 'planet-cage' and gear ring, the pawls (17) or (17^x) and clutch or ratchet teeth (16) will still give the normal gear.

Having now particularly described and ascertained the nature of my said invention and in what manner the same is to be performed I declare that what I claim is:—

1:—In variable gearing for velocipedes and road motor vehicles, the combination and arrangement of parts substantially as herein described in reference to and as illustrated by Figs. 1 to 11 of the accompanying drawings.

2:—In variable gearing for velocipedes and road motor vehicles, the combination and arrangement of parts substantially as herein described in reference to and as illustrated by Figs. 12 to 14 of the accompanying drawings.

3:—In variable gearing for velocipedes and road motor vehicles, a wheel hub having pawls (or a ring of clutch teeth) upon its interior, and a hub-bush having clutch teeth; a fixed and slotted (or grooved) axle having a fixed pinion; a driving sleeve with clutch teeth; and 'planet-cage' and gear ring devices, with clutch, spur, ratchet teeth and pinions, loosely coupled together, and capable of moving laterally along the axle and engaging the said pinion on the axle, the driving sleeve, the hub-bush and hub (or pawls), or allowing the pawls to engage the driving sleeve substantially as and for the purposes set forth.

4:—In variable gearing for velocipedes and road motor vehicles, a 'planet-cage' comprising a tubular part, a series of studs, pinions and clutch teeth; a gear ring consisting of a tubular part having spur, clutch and ratchet (or spur and clutch) teeth; means for loosely coupling the same and in combination (or otherwise) with means for laterally moving the same, substantially as and for the purposes set forth.

5:—In variable gearing for velocipedes and road motor vehicles, a 'planet-cage' comprising a tubular part, a series of studs, pinions and clutch teeth, in combination (or otherwise) with means for moving it laterally, substantially as and for the purposes set forth.

6:—In variable gearing for velocipedes and road motor vehicles, a gear ring consisting of a tubular part having spur, clutch and ratchet teeth (or spur and clutch teeth only), and with (or without) an annular groove with sloping sides, and in combination (or otherwise) with means for moving it laterally, substantially as and for the purposes set forth.

Improvements in Variable Gearing for Velocipedes and Road Motor Vehicles.

7:—In variable gearing for velocipedes and road motor vehicles, a wheel hub with pawls (or clutch teeth) and a hub-bush with clutch teeth; a driving sleeve with clutch teeth, a laterally moving 'planet-cage' and gear ring adapted to allow the pawls to engage and disengage the driving sleeve, and with (or without) a 'free wheel' attached thereto, substantially as and for the purposes set forth. 5

8:—In variable gearing for velocipedes and road motor vehicles, a wheel hub having pawls (or an inner ring of clutch teeth); a hub-bush or cup bearing having clutch teeth; a driving sleeve having clutch teeth; and a ring or bush with ball race fitting against shoulders on the sleeve and hub, substantially as and for the purposes set forth. 10

Dated this 25th day of March 1902.

JAMES ARCHER,
By John G. Wilson & Co.,
Chartered Patent Agents,
Manchester, 15

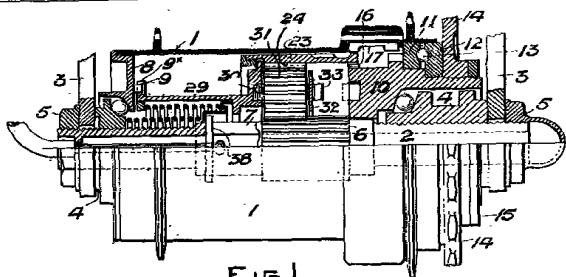

FIG. 1.

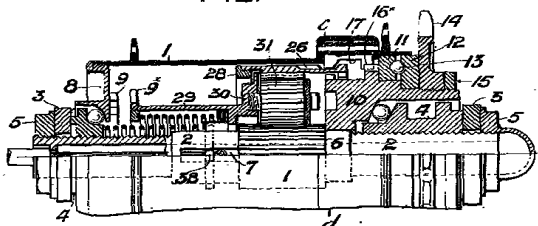

FIG. 2.

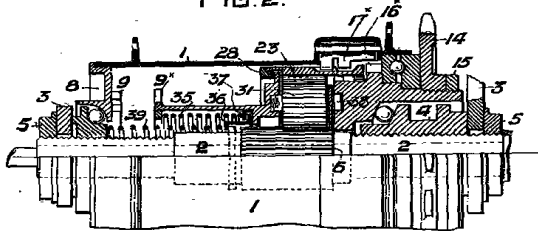

FIG. 3.

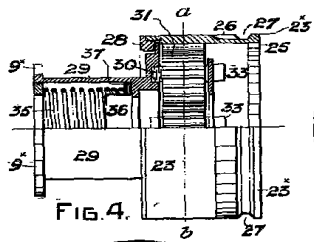

FIG. 4.

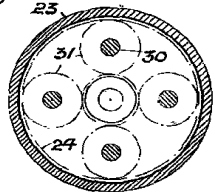

FIG. 5.

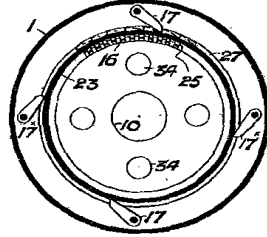

FIG. 6.

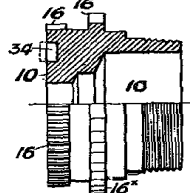

FIG. 7.

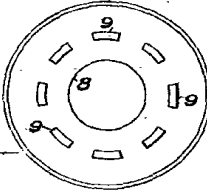

FIG. 8.

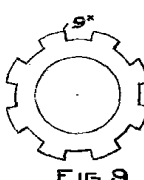

FIG. 9.

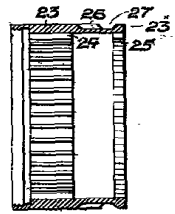

FIG. 10.

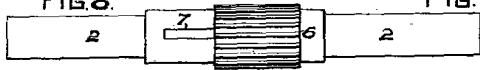

FIG. 11.

This Drawing is a reproduction of the Original on a reduced scale.

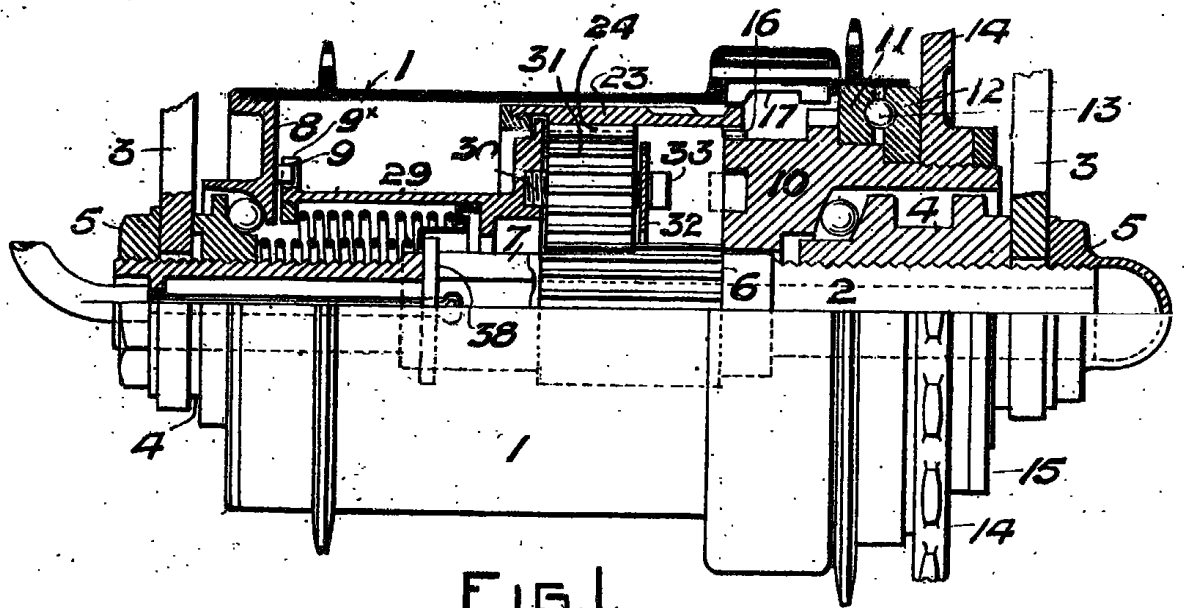

FIG. 1.

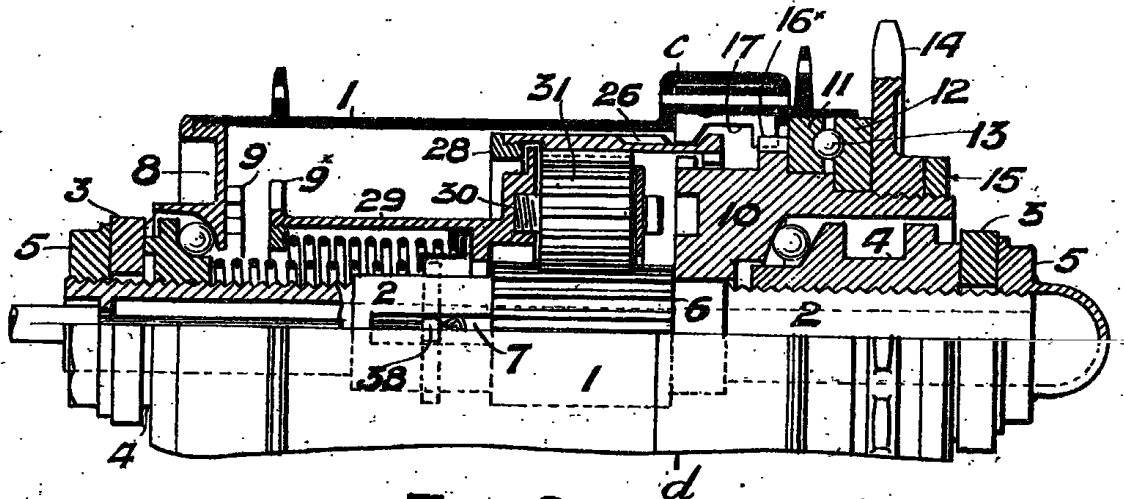

FIG. 2.

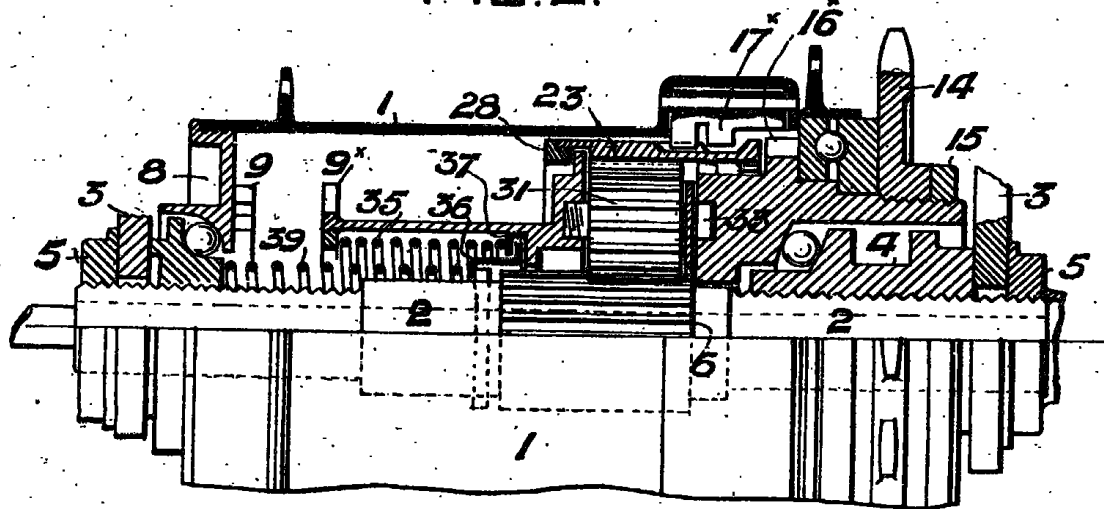

FIG. 3.

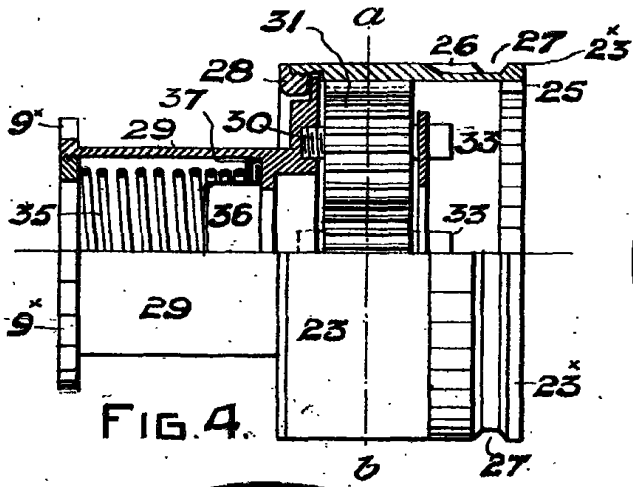

FIG. 4.

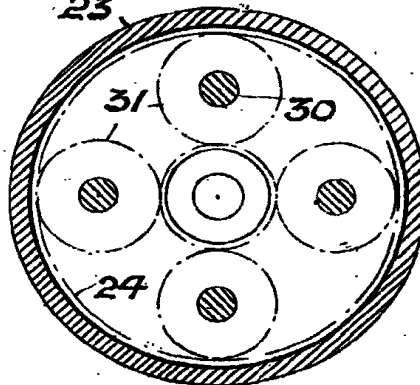

FIG. 5.

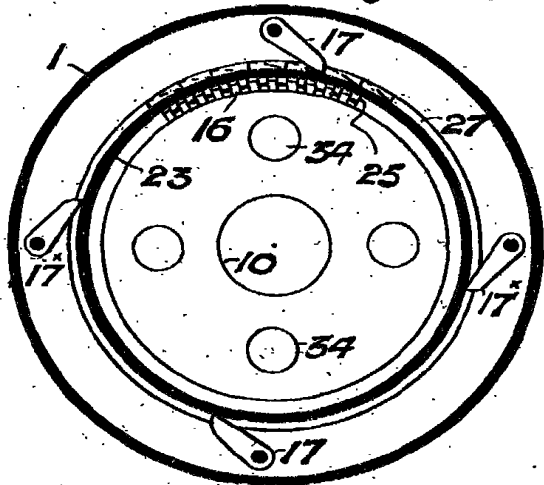

FIG. 6.

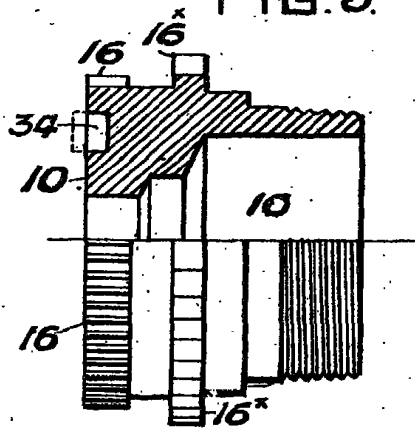

FIG. 7.

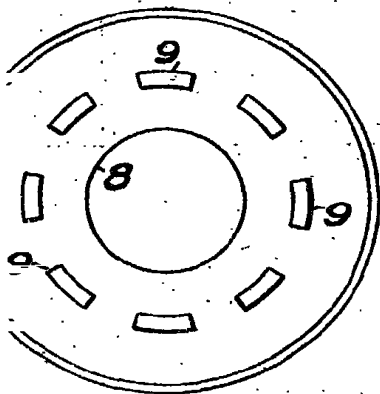

FIG. 8.

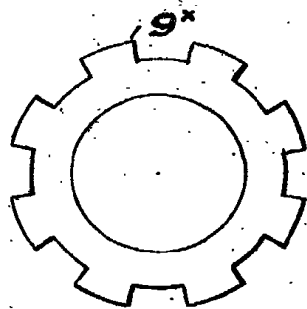

FIG. 9.

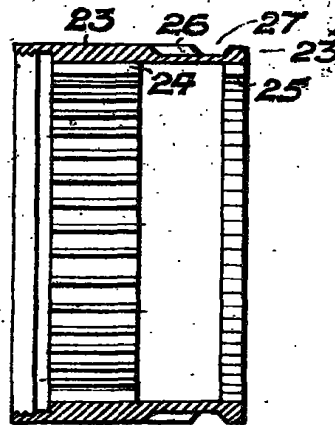

FIG. 10.

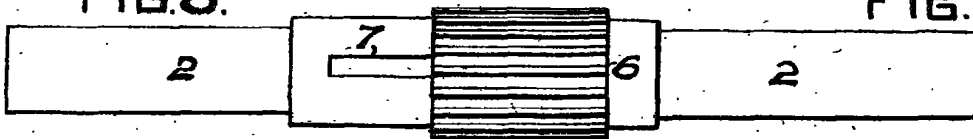
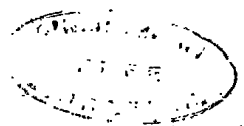

FIG. 11.

[This Drawing is a reproduction of the Original on a reduced scale.]



AMENDED SPECIFICATION.

Reprinted as amended in accordance with the decision of the Chief Examiner dated the 22nd. day of November, 1902.

N° 15,638



A.D. 1901

Date of Application, 2nd Aug., 1901

Complete Specification Left, 1st May, 1902—Accepted, 12th June, 1902

PROVISIONAL SPECIFICATION

Improvements in Variable Gearing for Velocipedes and Road Motor Vehicles.

I, JAMES ARCHER of 17 Linwood Street, Hulme, Manchester, Cycle Engineer, do hereby declare the nature of my said invention to be as follows:—

This invention relates chiefly to the driving gear of velocipedes and its object is to provide mechanism by which the rider may have the option of using three
5 different gears or speeds, 'low', 'high,' 'normal' and a 'free wheel' as desired, and so constructed and arranged that the rider may change the gears whilst riding. A further object is to so construct the parts that the 'high' and 'low' gear mechanism may be applied to or removed from the machine without affecting the 'normal' gear.

10 According to the invention and as applied to the rear wheel of safety bicycle I provide one end of the hub with a cup bearing and upon the inner side of such bearing I form or provide a clutch. The other end of the hub I provide with a ring or bush which fits neatly and detachably in the hub up to a shoulder or abutment. This ring has a ball race on one side and a similar ring
15 adjoins it with a like race. This latter is identified with a sleeve (hereafter called the driving sleeve) and upon such sleeve is mounted the usual sprocket or chain wheel. Such driving sleeve is also formed with a cup bearing at one end and at the other end within the hub is formed or provided with two clutches.

In the hub is an annular cavity and in such cavity a set of pawls.

20 Such annular cavity and pawls may be replaced by a fixed annular clutch.

Within the hub is a further sleeve (hereinafter called the gear ring) having
25 internal teeth formed at one end and capable of endwise and rotary movement. In the periphery of such gear ring is a ring of ratchet teeth, also an annular recess with inclined sides, and the position of the gear ring, and its movements in relation to the pawls in the hub cavity, are such that the pawls may engage the ratchet teeth, and act as a 'free wheel' in one direction, or be raised on to the plain part of the gear ring entirely out of action.

This gear ring has a clutch on one end adapted to engage with one of the
30 clutches on the driving sleeve, and when so engaged, the pawls may, by means of the inclines of the annular recess aforesaid, be raised out of action.

Within the gear ring I arrange a 'planet-cage,' carrying, upon studs and
between suitable flanges, three or more planet pinions meshing with a pinion concentric with the axle, also with the said inner teeth on the gear ring, and upon each end of the 'planet-cage' I form further clutches, and such clutches are
35 directly in line with, and respectively opposite to, the clutches on the cup bearing, and the driving sleeve. The 'planet-cage' and gear ring are laterally coupled

[Price 8d.]

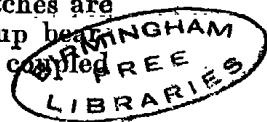

Improvements in Variable Gearing for Velocipedes and Road Motor Vehicles.

together and the endwise movements of the same are such that as the clutch of the gear ring engages with one of the clutches on the driving sleeve, the clutch of the 'planet-cage' engages with the hub (or *vice versa*) thus giving a change of gear. When both clutches are disengaged the pawls in the hub engage the driving sleeve and thus give the 'normal' gear. 5

In such way, and by such means I provide three changes of gear 'high', 'low,' 'normal,' and allow for the ready introduction or withdrawal of the 'high' and 'low' speed gears from the hub without altering the 'normal' gear.

The pinion on the axle is a fixture.

The sprocket wheel may be loose on the driving sleeve and be fitted with free 10 wheel devices, but I prefer it to be fast and to be held by a nut or screwed ring screwing against it. Other variations in details may be made, and the position of the gears varied without departing from my invention.

The endwise movements of the mechanism may be secured by means of a sliding feather within the axle, or by a hollow spindle and cross feather engag- 15 ing with the 'planet cage,' or by any suitable device.

Dated this 1st day of August 1901.

JAMES. ARCHER,

By John, G. Wilson & Co.
Manchester, Agents. 20

COMPLETE SPECIFICATION (AMENDED).

Improvements in Variable Gearing for Velocipedes and Road Motor Vehicles.

I, JAMES ARCHER of 17 Linwood Street, Hulme, Manchester, Cycle Engineer, do hereby declare the nature of this invention and in what manner the same is to 25 be performed, to be particularly described and ascertained in and by the following statement;—

This invention relates chiefly to the driving gear of velocipedes, and its object is to provide mechanism by which the rider may have the option of using three different gears or speeds 'low,' 'normal,' 'high' and a 'free wheel' as 30 desired, and so constructed and arranged that the rider may change the gears whilst riding. A further object is so to construct the parts that the 'high' and 'low' gear mechanism may be applied to, or removed from the machine without affecting the 'normal' gear.

According to the invention, and as applied to the rear wheel of a safety 35 bicycle, I provide one end of the hub with a cup bearing, and upon the inner side of such bearing I form or provide a clutch. The other end of the hub I provide with a ring or bush which fits neatly and detachably in the hub up to a shoulder or abutment. This ring has a ball race on one side and a similar ring adjoins it with a like race. This latter is identified with a sleeve (hereinafter 40 called the driving sleeve) and upon such sleeve is mounted the usual sprocket or chain wheel. Such driving sleeve is also formed with a cup bearing at one end, and at the other end with in the hub is formed or provided with two clutches. In the hub is an annular cavity and in such cavity a set of pawls. Such annular cavity and pawls may be replaced by a fixed annular clutch. 45

Within the hub is a further sleeve (hereinafter called the gear ring) having internal teeth formed at one end and capable of endwise and rotary movement. In the periphery of the gear ring is a ring of ratchet teeth, also an annular recess with inclined sides, and the position of the gear ring and its movements in relation to the pawls in the hub cavity are such that the pawls may engage the 50

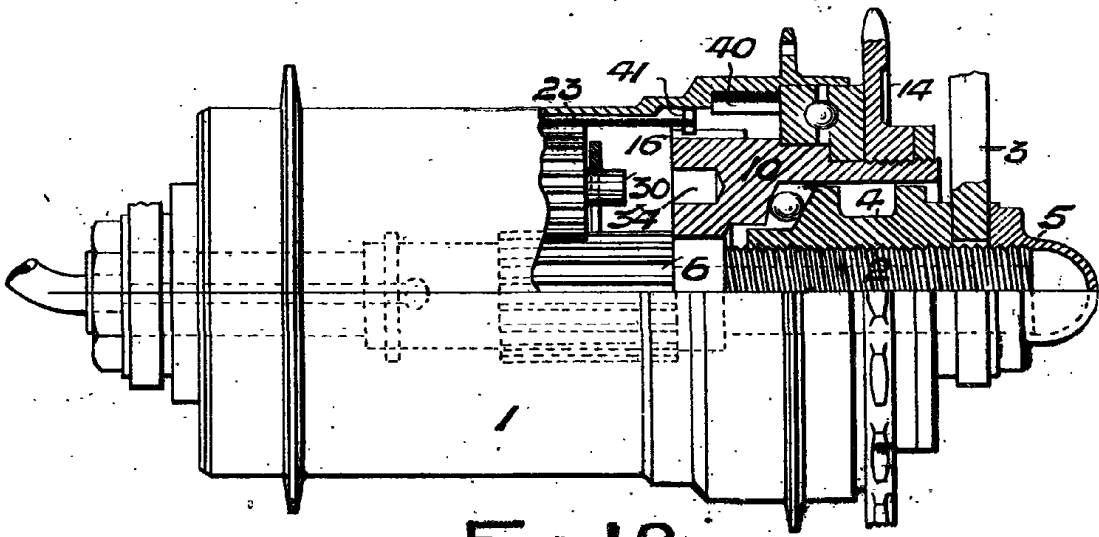

FIG. 12.

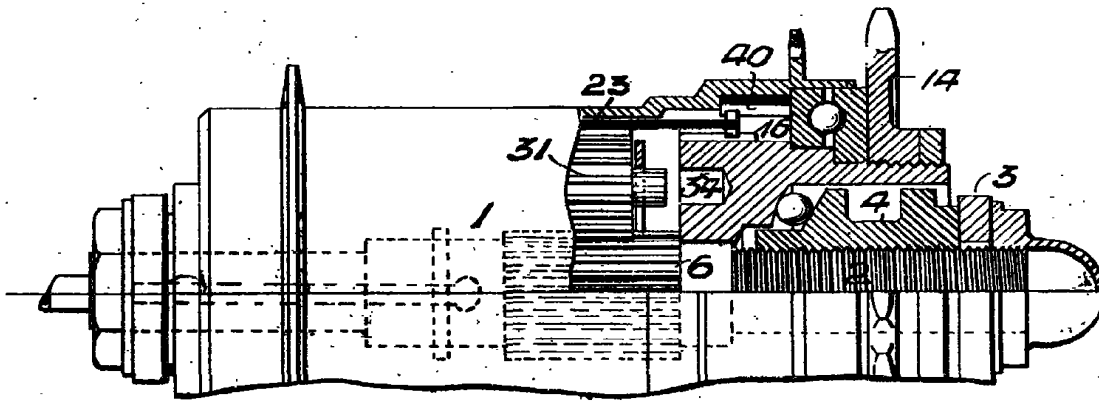

FIG. 13.

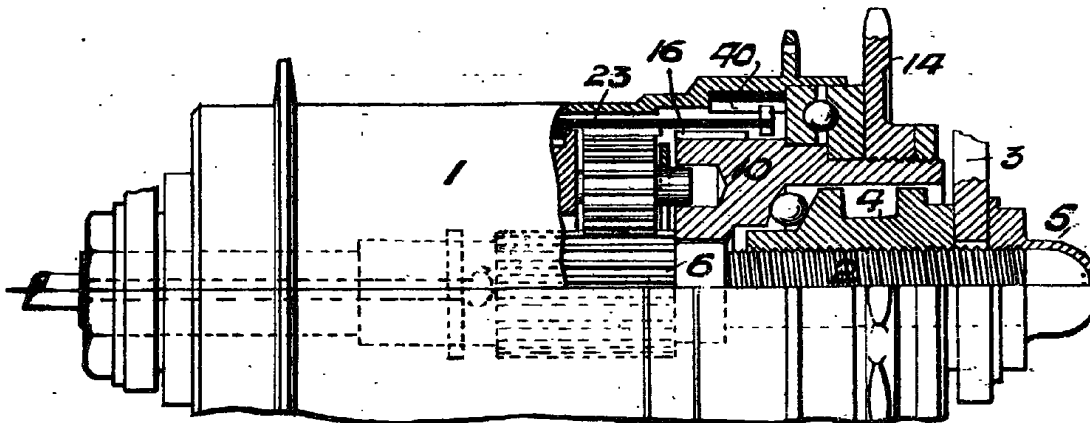

FIG. 14.

[This Drawing is a reproduction of the Original on a reduced scale.]

Improvements in Variable Gearing for Velocipedes and Road Motor Vehicles.

ratchet teeth and act as a 'free wheel' in one direction, or be raised on to the plain part of the gear ring entirely out of action. When the pawls engage the ratchet teeth of the gear ring the hub is driven at the 'high' gear.

5 This gear ring has a clutch on one end adapted to engage with one of the clutches on the driving sleeve.

Within the gear ring I arrange a 'planet-cage' carrying upon studs and between suitable flanges three or more planet pinions meshing with a pinion concentric with the axle, also with the said inner teeth on the gear ring, and upon each end of the 'planet-cage' I form further clutches, and such clutches
10 are directly in line with and respectively opposite to clutches on the cup bearing and the driving sleeve. The 'planet-cage' and gear ring are laterally coupled together and the endwise movements of the same are such that as the clutch of the gear ring engages with one of the clutches on the driving sleeve, the clutch of the 'planet-cage' engages with the hub, thus giving a change of gear.

15 When both clutches are disengaged the pawls in the hub engage the driving sleeve, and thus give the 'normal' gear. In such way and by such means I provide for three changes of gear 'high,'—'low,'—'normal,'—and allow for the ready introduction or withdrawal of the 'high' and 'low' speed gears from the hub without altering the 'normal' gear.

20 The pinion on the axle is a fixture.

The sprocket wheel may be loose on the driving sleeve and be fitted with 'free wheel' devices, but I prefer it to be fast and to be held by a nut or screwed ring screwing against it. Other variations in details may be made and the position of the gears varied without departing from my invention.

25 The endwise movements of the mechanism may be secured by means of a sliding feather in the axle, or by a hollow spindle and cross-feather engaging with the 'planet-cage,' or by any suitable device.

To permit of my invention being more clearly understood I have hereunto appended 2 sheets of drawings, wherein

30 Fig. 1 illustrates a longitudinal elevation, partly sectional, of a wheel hub fitted with my invention and as adapted for giving the three gears,—'low', 'normal' 'high' and the 'high' and 'normal' gears 'free.' Such view also shews the position of the parts for the 'low' gear.

35 Figs. 2 and 3 illustrate like views, but Fig. 2 shews a plan and the position of the parts for giving the 'normal' gear and Fig. 3 shews the position of the parts for giving the 'high' gear.

Fig. 4 illustrates a half-exterior and half-longitudinal section of the 'planet-cage' and gear ring. Fig. 5 illustrates a cross section on lines *a—b*.

40 Fig. 6 illustrates a transverse section of Fig. 2 on line *c—d*, and Fig. 7 illustrates a half-exterior and half-longitudinal section of the 'driving sleeve'.

45 Fig. 8 illustrates an inner side view of the hub-bush or cup bearing shewn at the left hand end of Fig. 1, and part of the 'low' gear, and Fig. 9 illustrates a side view of the left hand end of the 'planet-cage', and another part of the 'low' gear. Fig. 10 illustrates a sectional view of the gear ring alone, and Fig. 11 illustrates a detached view of the wheel axle. Figs. 12, 13 and 14 illustrate a modification, and the several positions of the gears for the three speeds.

Referring to Figs. 1 to 11,—(1) is the hub of say the rear wheel of a safety bicycle more or less of ordinary construction. Within such hub is the hollow axle (2) held stationary, relatively to the hub, by the usual forks or members (3)
50 of the bicycle frame, the ball bearings (4) and nuts (5). Upon, or formed in such axle is a fixed ring of gear teeth, constituting a fixed pinion (6), and in a plain portion of such axle is a slot (7). In one end of the hub, and supporting the hub concentric to the axle, is the bush or cup bearing (8), and upon the inner face of such bush are clutch teeth (9).

55 At the other end of the hub, and supporting the hub concentric with the axle at that end, is the ball bearing (4) aforesaid, the sleeve or bush (10) (hereinafter and previously called the driving sleeve) see Fig. 7, and the ball race rings

Improvements in Variable Gearing for Velocipedes and Road Motor Vehicles.

(11), (12), with anti-friction balls (13) between them, and fitting against a shoulder in the hub as shewn.

Upon the driving sleeve is the chain or sprocket wheel (14) held tightly thereon and against the ring (12) by the clamping nut (15).

Upon the periphery of the driving sleeve within the hub are the two rings of clutch teeth (16), (16^x), the latter being, by preference in the form of ratchet teeth and upon the interior of the hub are the pawls (17), (17^x). The pawls (17) are of the shape shewn in Fig. 1 and 2, and the pawls (17^x) are of the shape shewn in Fig. 3.

Within the hub, and surrounding the axle, is the gear ring (23), see Fig. 10, having an internal ring of gear teeth (24), an internal ring of clutch teeth (25), an external ring of ratchet teeth (26), and an annular groove (27) with inclined sides. Coupled laterally and loosely by a ring (28) to such gear ring is the 'planet-cage', comprising a tubular part (29) carrying studs (30), and pinions (31) loosely mounted on the said studs, and held thereon by a flange (32) having clutch teeth (or nipples) (33). The pinions (31) mesh at all times with the pinion (6) on the axle.

Upon the tubular part (29) are also the clutch teeth (9^x). In the driving sleeve (10) is a clutch (34), either in the form of holes, or teeth and corresponding in spacing from each other and in the distance from the axle (2) with the spacing and distance of the teeth (33).

With the 'planet-cage' and gear ring in the position shewn in Fig. 1 the hub is driven at the 'low' speed, the driving taking place through the clutch teeth (16) and (25), the gear ring (23), the pinions (31), studs (30), tubular part (29) and the clutch teeth (9) and (9^x), the pinion (6) offering the necessary resistance to cause the pinions (31) to rotate on their studs (30) as they are rolled around the axle by the teeth (24) and thus reduce the speed. The pawls (17), (17^x) both rest upon the plain part (23^x) of the gear ring.

With the 'planet-cage' and gear ring in the position shewn in Fig. 2 the hub is driven at the 'normal' speed, the driving taking place direct through the teeth (16^x) and pawls (17) the planet-cage and gear ring being idle.

With the 'planet-cage' and gear ring in the position shewn in Fig. 3 the hub is driven at the 'high' speed,—the driving taking place through the teeth or bosses (33) engaging the holes (or teeth) (34), pinions (31), gear ring (23), the ratchet teeth (26) and pawls (17^x). At such speed the pawls (17) rotating faster slip over the teeth (16^x), the pawls (17^x) alone effecting the drive and hence the two sets of pawls.

The means for bringing about the lateral movements of the 'planet-cage' and gear ring may vary, but in practice I have found the arrangement of cord, cross-bar and springs covered by my application for Letters Patent, No. 519, A.D. 1902 as the most satisfactory, and in now describing and illustrating the same I hereby give public notice that I do not dedicate the said devices, or any part thereof, not claimed in this specification to the public, but simply refer to them as being the best means known to me for the said purpose.

Within the tubular (29) is a spiral spring (35), also a thimble-like part (36) with contact ring (37), and in the slot (7) of the axle is the cross-bar or feather (38), the ends of which project on each side of the axle and normally lie behind the flanged end of the thimble-like part (36) as shewn. To such cross-bar is attached one end of say a 'Bowden' wire, or the like the other end of which passes out through the open end of the axle and from thence extends to the point from which the gears are to be operated.

Around the axle (2) and within the spring (35) I place a further spring (39). Under the elongation of this spring the normal position of the parts is as shewn in Fig. 3. To obtain the 'normal' gear the cord is pulled and the bar (38) thereby caused to press against the thimble-like part (36) and through the spring (35), move the 'planet-cage' and gear ring to the position shewn in Fig. 2, the spring (39) being thereby slightly compressed.

Improvements in Variable Gearing for Velocipedes and Road Motor Vehicles.

To obtain the 'low' gear the cord is given a further pull, thereby causing the bar (38) to move the 'planet-cage' and gear ring to the position shewn in Fig. 1, the spring (39) being thereby still further compressed.

Should the clutches (9), (9^x) not be relatively opposite the spring (35) is slightly compressed so that immediately the gears rotate the clutches engage under the elongation of the spring (35). Upon the cord being relaxed, the spring (39) serves to change the gears by its elongation.

Referring to Figs. 12, 13 and 14, a fixed clutch ring (40) is substituted for the pawls (17), (17^x), and the clutch teeth (41) for the ratchet teeth (26). The ratchet teeth (16) are dispensed with, and the clutch teeth (16) are made wider, and in lieu of the flange (32) with clutch teeth (33) I use the studs (30) engaging with clutch recesses or holes (34^x) thereby simplifying the construction.

The position of the parts for the 'low' gear is as shewn in Fig. 12, the position of the parts for the 'normal' gear is as shewn in Fig. 13, and the position of the parts for the 'high' gear is as shewn in Fig. 14. All the gears in this modification are 'fixed' in both directions. To obtain the 'free wheel' effect for each gear I employ an ordinary 'free wheel' attachment, in lieu of the sprocket wheel (14).

The several clutches may be in the form of segmental teeth, or in the form of spur teeth, or ratchet teeth.

Whilst chiefly for velocipede use my invention applies equally to road motor vehicles, and in the case of Figs. 1, 2 and 3 it will be seen that by removing the 'planet-cage' and gear ring, the pawls (17) or (17^x) and clutch or ratchet teeth (16^x) will still give the normal gear.

Having now particularly described and ascertained the nature of my said invention and in what manner the same is to be performed I wish it to be understood that I am aware that it is not new to employ epicyclic gear for varying the speed of cycles or motor road vehicles and that it is not new with such variable speed gear to employ a hollow axle, a sliding sleeve, controlling springs and a cord or its equivalent for bringing about the changes of gear and therefore I make no general claim thereto but I declare that what I claim is:—

1:—In variable gearing for velocipedes and road motor vehicles, the combination and arrangement of parts substantially as herein described in reference to and as illustrated by Figs. 1 to 11 of the accompanying drawings.

2:—In variable gearing for velocipedes and road motor vehicles, the combination and arrangement of parts substantially as herein described in reference to and as illustrated by Figs. 12 to 14 of the accompanying drawings.

3:—In variable gearing for velocipedes and road motor vehicles, a wheel hub having pawls (or a ring of clutch teeth), upon its interior, and a hub-bush having clutch teeth; a fixed and slotted (or grooved) axle having a fixed pinion; a driving sleeve with clutch teeth; and 'planet-cage' and gear ring devices (with clutch, spur, ratchet teeth and pinions) loosely coupled together, and capable of moving laterally along the axle and engaging the said pinion on the axle, the driving sleeve, the hub-bush and hub (or pawls), or allowing the pawls to engage the driving sleeve, substantially as and for the purposes set forth.

4:—In variable gearing for velocipedes and road motor vehicles, a 'planet-cage' comprising a tubular part, a series of studs, pinions and clutch teeth; a gear ring consisting of a tubular part having spur, clutch and ratchet (or spur and clutch) teeth; means for loosely coupling the same, and in combination (or otherwise) with means for laterally moving the same, substantially as and for the purposes set forth.

5:—In variable gearing for velocipedes and road motor vehicles, a 'planet-cage' comprising a tubular part, a series of studs, pinions and clutch teeth, in combination (or otherwise) with means for moving it laterally, substantially as and for the purposes set forth.

6:—In variable gearing for velocipedes and road motor vehicles, a gear ring

Improvements in Variable Gearing for Velocipedes and Road Motor Vehicles.

consisting of a tubular part having spur, clutch and ratchet teeth (or spur and clutch teeth only), and with (or without) an annular groove with sloping sides, and in combination (or otherwise) with means for moving it laterally, substantially as and for the purposes set forth.

7:—In variable gearing for velocipedes and road motor vehicles, a wheel hub 5 with pawls (or clutch teeth) and a hub-bush with clutch teeth; a driving sleeve with clutch teeth, a laterally moving 'planet-cage' and gear ring adapted to allow the pawls to engage and disengage the driving sleeve, and with (or without) a 'free wheel' attached thereto, substantially as and for the purposes set forth.

8:—In variable gearing for velocipedes and road motor vehicles, a wheel hub 10 having pawls (or an inner ring of clutch teeth); a hub-bush or cup bearing having clutch teeth; a driving sleeve having clutch teeth; and a ring or bush with ball race fitting against shoulders on the sleeve and hub, substantially as and for the purposes set forth.

Dated this 25th day of March 1902.

JAMES ARCHER
By John G. Wilson & Co.,
Chartered Patent Agents, Manchester.

15

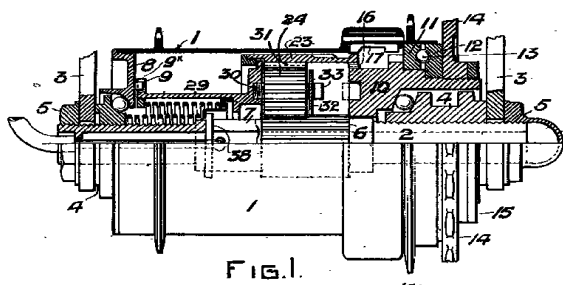

FIG. 1.

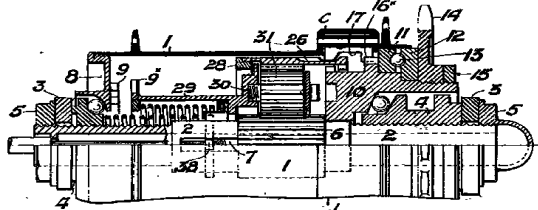

FIG. 2.

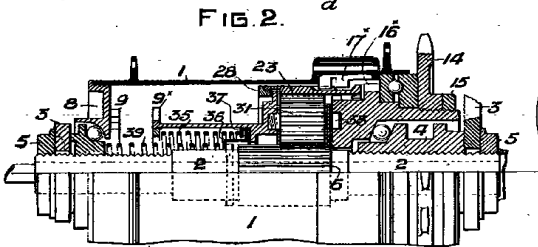

FIG. 3.

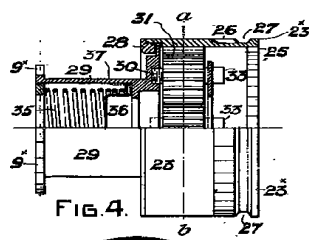

FIG. 4.

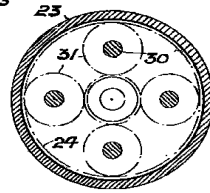

FIG. 5.

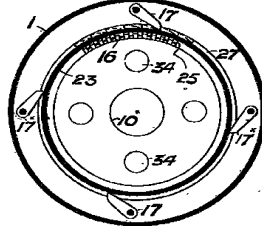

FIG. 6.

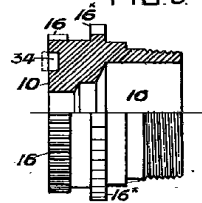

FIG. 7.

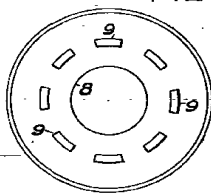

FIG. 8.

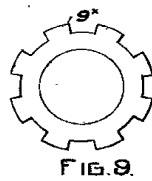

FIG. 9.

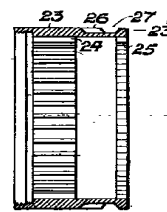

FIG. 10.



FIG. 11.

This Drawing is a reproduction of the Original on a reduced scale.

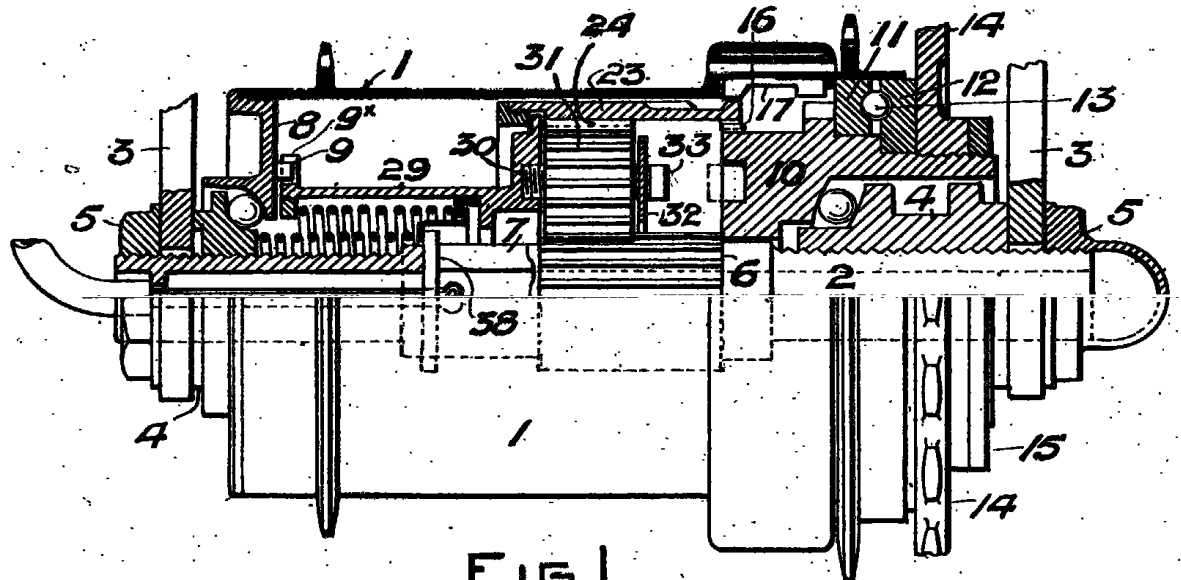

FIG. 1.

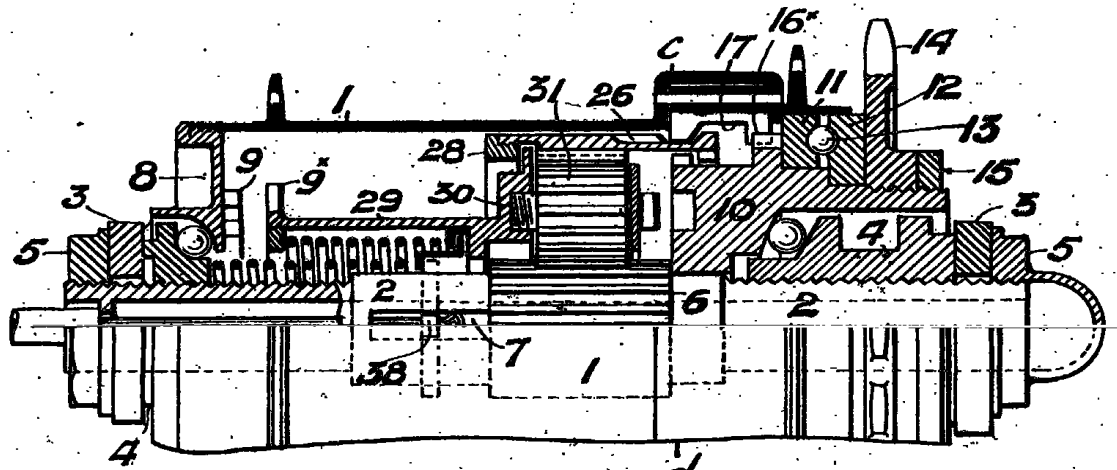

FIG. 2.

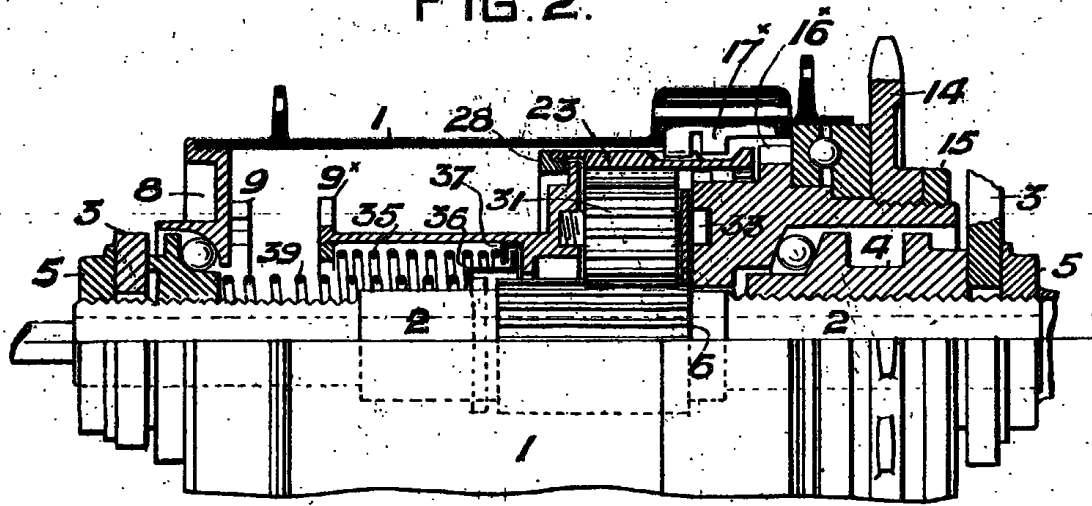

FIG. 3.

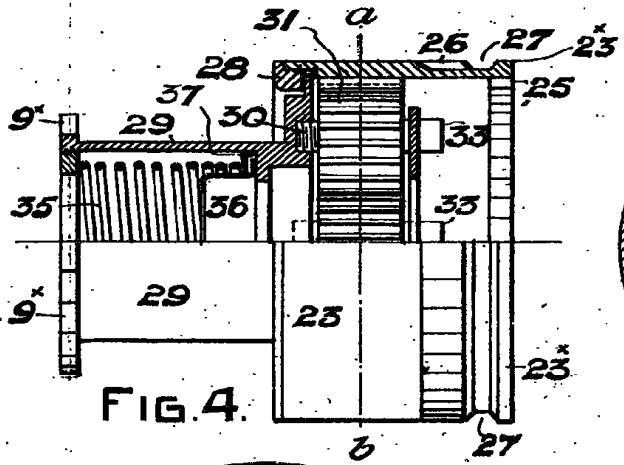

FIG. 4.

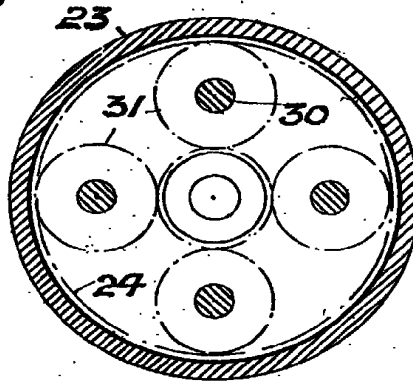

FIG. 5.

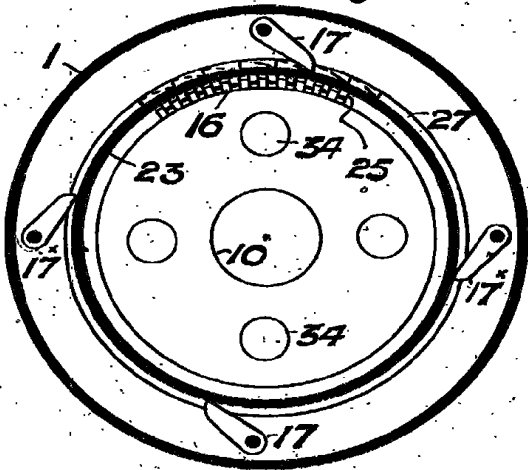

FIG. 6.

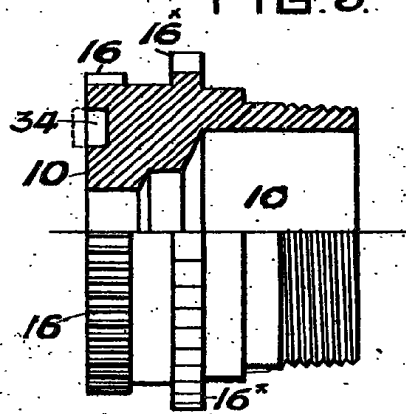

FIG. 7.

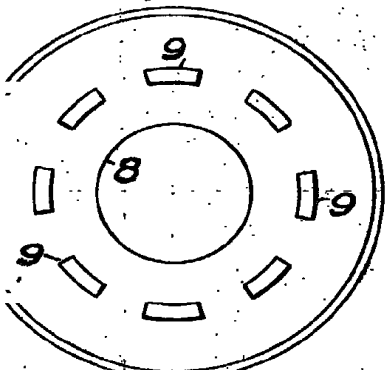

FIG. 8.

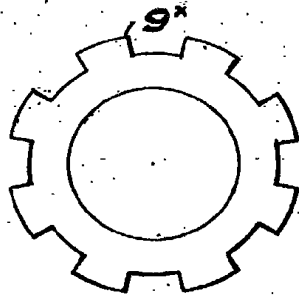

FIG. 9.

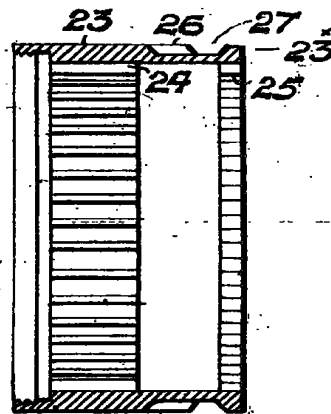

FIG. 10.

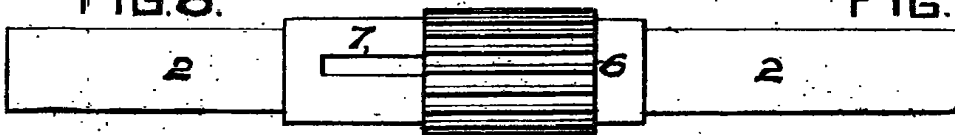

FIG. 11.

[This Drawing is a reproduction of the Original on a reduced scale.]

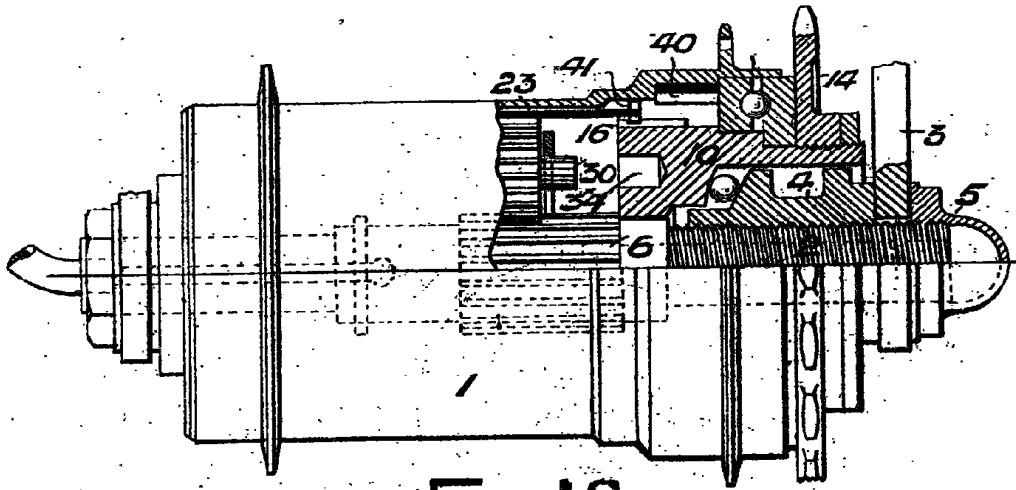

FIG. 12.

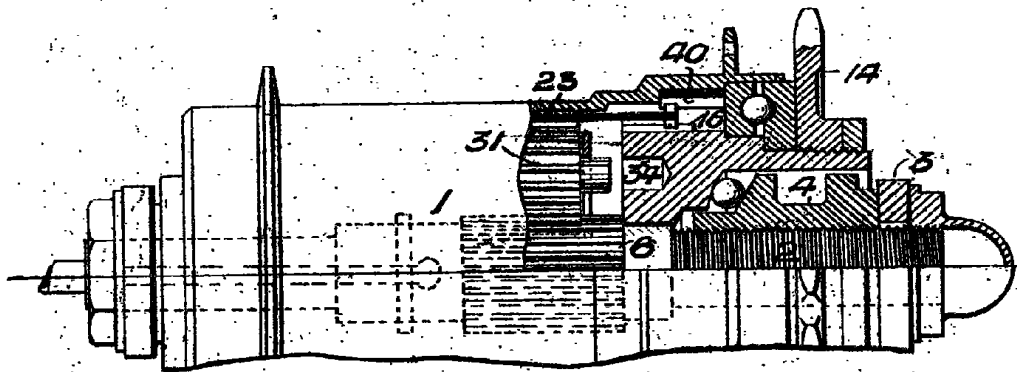

FIG. 13.

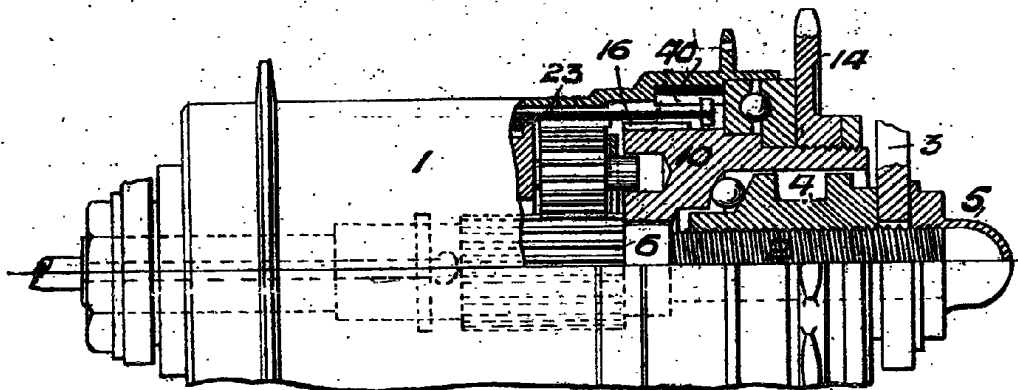

FIG. 14.

[This Drawing is a reproduction of the Original on a reduced scale.]